

7	FEMALE PILOT PIN CRIMP CAL.4	899.SP2FP04	2	19
6	MALE PHASE CONTACT CAL.10	899.SP2MC10	4	
5	LONG INSERT (SOCKET) 4P+E	899.SP2SI4	1	
4	SCREW TERM.50 ² -70 ² EA/PH 4P+E	899.SP2FE70S		26
	CRIMPING TERM.70 ² EA/PH 4P+E	899.SP2FE70		29
3	CONNECTOR CASING		1	
2	FEMALE EARTH CONTACT CAL.10	899.SP2FE10	1	
1	CABLE GLAND SEAL Ø54		1	

Ind	Description	Reference	Cont.	Strip. A
-----	-------------	-----------	-------	----------

PRODUCT REFERENCE

899.AS2CE450V
899.AS2CE470

SCAME
S.p.A.
PARRE - (Bergamo)
zp90982-25-2_mp39414

ASSEMBLY INSTRUCTIONS

- 1- PREPARE THE CABLES AS SCHEME BELOW.
- 2- CRIMP OR SOLDER CABLE TERMINALS (4) ON PHASE CABLES AND EARTH CABLE [TOOL Nr 7 AND 8].
- 3- UNSCREW HANDLE (3.4) [TOOL Nr 4] AND CABLE GLAND (3.2).
- 4- IN THE ORDER, SLIDE CABLE GLAND (3.2), WASHER (3.3), SEAL (1) AND HANDLE (3.4) OVER THE CABLE.
- 5- ENGAGE EARTH CONTACT (2) IN THE HOLE OF EARTH EAR IN THE MIDDLE OF CONNECTOR CASING (3).
- 6- PLACE CABLE TERMINAL (4) OF EARTH CABLE AT THE BACKSIDE OF EARTH CONTACT (2), SCREW CONTACT, WHEN CABLE TERMINAL HEXAGON TOUCH EARTH EAR OF CONNECTOR CASING (3), PUSH IT INSIDE OF EARTH EAR TO BLOCK IT, THEN TIGHTEN CONTACT (2) (TORQUE 4Nm) [TOOL Nr 1 AND 2].
- 7- REMOVE SCREWS OF CONTACTS (7) [TOOL Nr 6], INTRODUCE CONTACTS IN FRONT OF IP2X PHASE CONTACT CARRIER (5). INTRODUCE PILOT CABLES IN BACKSIDE OF CONTACTS AND PUT SCREWS IN CONTACTS THEN TIGHTEN [TOOL Nr 6].
- 8- INTRODUCE EACH CABLE TERMINAL (4) AT THE BACKSIDE OF IP2X PHASE CONTACT CARRIER (5), HEXAGON OF CABLE TERMINAL MUST CORRESPOND WITH HEXAGON INSIDE OF THE IP2X PHASE CONTACT CARRIER, THEN SCREW CONTACTS (6) IN THE FRONT OF IP2X PHASE CONTACT CARRIER (TORQUE 4Nm) [TOOL Nr 1 AND 2].
- 9- INTRODUCE IP2X PHASE CONTACT CARRIER (5) IN CONNECTOR CASING (3) AND FIX HANDLE (3.4) [TOOL Nr 4].
- 10- PLACE SEAL (1) AND WASHER (3.3) INTO HANDLE (3.4) THEN SCREW CABLE GLAND (3.2) TO BE WATERPROOF.
- 11- TIGHTEN SCREWS AND NUTS OF CABLE CLAMPS (3.1) ON CABLE TO BLOCK CABLE GLAND (3.2) [TOOL Nr 3].

LIST OF TOOLS *

- 1- TORQUE WRENCH FACOM REF. J.306A50
- 2- SOCKETS FACOM : 3/8" Nr12 REF: J.12LA
3/8" Nr14 REF: J.14
- 3- ANGLED SOCKET WRENCH OR OPEN END WRENCH 13mm
- 4- ANGLED SOCKET WRENCH OR OPEN END WRENCH 10mm
- 5- ALLEN KEY Nr3
Nr4
- 6- FLAT SCREWDRIVER Nr 3
- 7- CRIMPING TOOL KLAUKE HK 120 U
- 8- KLAUKE CRIMPING JAW: 70° REF: HNFF 13/70

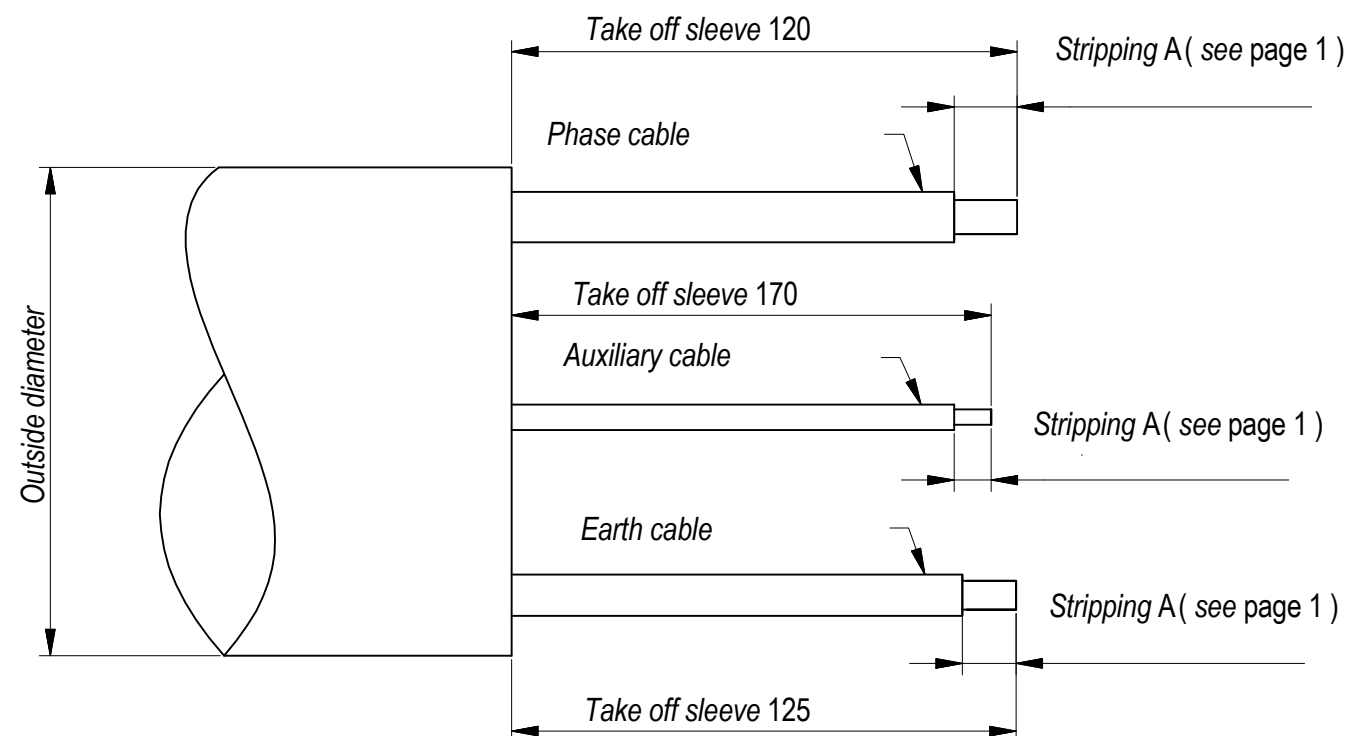

* TOOL REFERENCES ARE ONLY RECOMMENDED AND GIVEN AS EXAMPLES. TOOLS ARE NOT PROVIDED OR IMPOSED BY SCAME.

SCAME

S.p.A.

PARRE - (Bergamo)

zp90982-25-2_mp39414