

7	PLUG CASING		1	
6	MALE PILOT PIN CRIMP CAL.4	899.SP2MP04	2	19
5	FEMALE PHASE CAL.10	899.SP2FC10	4	
4	SHORT INSERT (PLUG) 4P+E	899.SP2PI4	1	
3	SCREW TERM.50 ² -70 ² EA/PH 4P+E	899.SP2FE70S		26
	CRIMPING TERM.70 ² EA/PH 4P+E	899.SP2FE70		29
2	CABLE GLAND SEAL Ø54		1	
1	MALE EARTH CONTACT CAL.10	899.SP2ME10	1	
Ind	Description	Reference	Cont.	Strip. A

PRODUCT REFERENCE

899.AS2PR450V
899.AS2PR470

SCAME
S.p.A.
PARRE - (Bergamo)
zp90982-23-2_mp39412

ASSEMBLY INSTRUCTIONS

- 1- PREPARE THE CABLES AS SCHEME BELOW.
- 2- CRIMP OR SOLDER CABLE TERMINALS (3) ON PHASE CABLES AND EARTH CABLE [TOOL Nr 7 AND 8]. FOR CABLE TERMINALS TO SCREW [TOOL Nr 5].
- 3- UNSCREW HANDLE (7.4) [TOOL Nr 3] AND CABLE GLAND (7.2).
- 4- IN THE ORDER, SLIDE CABLE GLAND (7.2), WASHER (7.3), SEAL (2), HANDLE (7.4) AND NUT (7.5) OVER THE CABLE.
- 5- ENGAGE EARTH CONTACT (1) IN THE HOLE OF EARTH EAR IN THE MIDDLE OF PLUG CASING (7).
- 6- PLACE CABLE TERMINAL (3) OF EARTH CABLE AT THE BACKSIDE OF EARTH CONTACT (1), SCREW CONTACT, WHEN CABLE TERMINAL HEXAGON TOUCH EARTH EAR OF BODY FRONT (7), PUSH IT INSIDE OF EARTH EAR TO BLOCK IT, THEN TIGHTEN CONTACT (1) (TORQUE 4Nm) [TOOL Nr 1 AND 2].
- 7- REMOVE SCREWS OF CONTACTS (6) [TOOL Nr 6], INTRODUCE CONTACTS IN FRONT OF INSERT (4). INTRODUCE PILOT CABLES IN BACKSIDE OF CONTACTS AND PUT SCREW IN CONTACTS THEN TIGHTEN [TOOL Nr 6].
- 8- INTRODUCE EACH CABLE TERMINAL (3) AT THE BACKSIDE OF FEMALE CONTACT CARRIER (4), HEXAGON OF CABLE TERMINAL MUST CORRESPOND WITH HEXAGON INSIDE OF THE FEMALE CONTACT CARRIER, THEN SCREW CONTACTS (5) IN THE FRONT OF FEMALE CONTACT CARRIER (TORQUE 4Nm) [TOOL Nr 1 AND 2].
- 9- INTRODUCE FEMALE CONTACT CARRIER (4) IN PLUG CASING (7) AND FIX HANDLE (7.4) [TOOL Nr 3]. DO NOT FORGET PLACE NUT (7.5) BETWEEN HANDLE (7.4) AND BODY FRONT (7).
- 10- PLACE SEAL (2) AND WASHER (7.3) INTO HANDLE (7.4) THEN SCREW CABLE GLAND (7.2) TO BE WATERPROOF.
- 11- TIGHTEN SCREWS AND NUTS OF CABLE CLAMPS (7.1) ON CABLE TO BLOCK CABLE GLAND (7.2) [TOOL Nr 4].

LIST OF TOOLS *

- 1- TORQUE WRENCH FACOM REF. J.306A50
- 2- SOCKETS FACOM : 3/8" Nr14 REF: J.14LA
- 3- ANGLED SOCKET WRENCH OR OPEN END WRENCH 10mm
- 4- ANGLED SOCKET WRENCH OR OPEN END WRENCH 13mm
- 5- ALLEN KEY Nr3
Nr4
- 6- FLAT SCREWDRIVER Nr 3
- 7- CRIMPING TOOL KLAUKE HK 120 U
- 8- KLAUKE CRIMPING JAW: 70° REF: HNFF 13/70

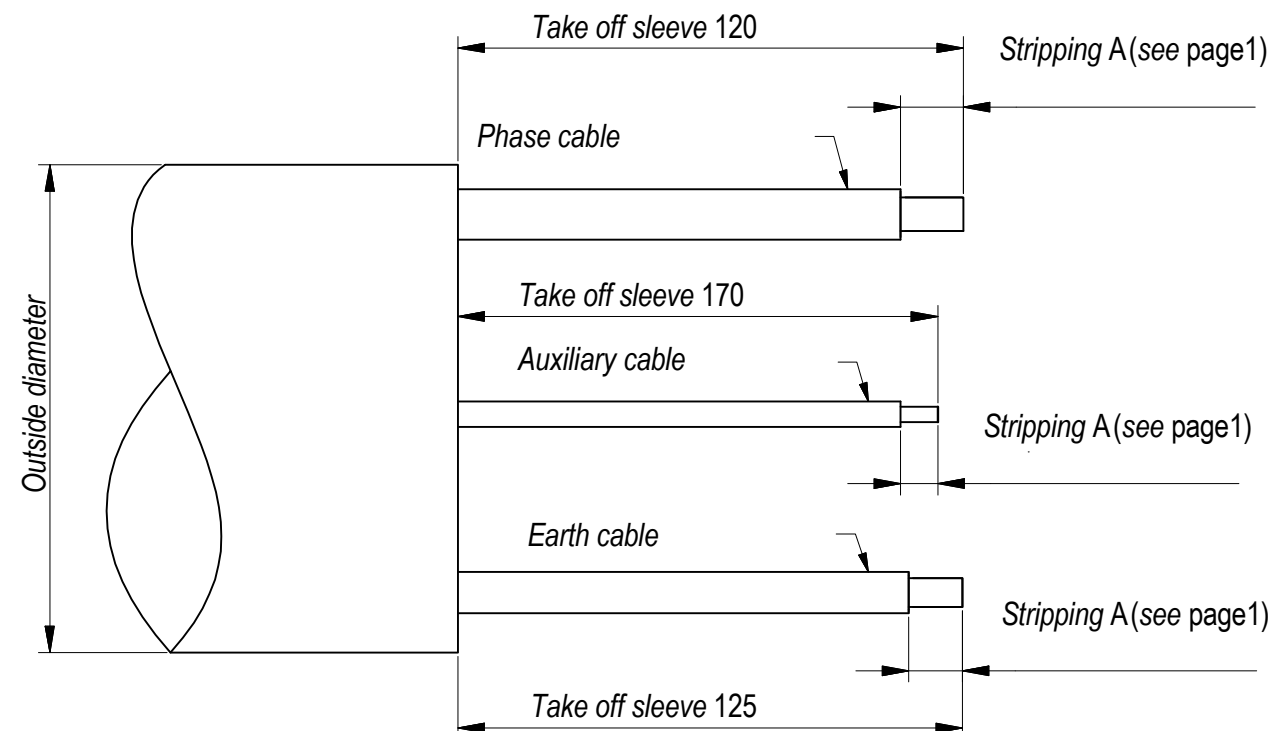

* TOOL REFERENCES ARE ONLY RECOMMENDED AND GIVEN AS EXAMPLES. TOOLS ARE NOT PROVIDED OR IMPOSED BY SCAME.