

6	EARTH PIN CAL.20		1	
5	APPLIANCE INLET CASING		1	
4	4+E CONTACT CARRIER		1	
3	AUXILIARY PIN CAL.4		2	19
	CABLE TERMINAL TO CRIMP OR SOLDER 300 ²			48
	CABLE TERMINAL TO CRIMP OR SOLDER 240 ²			42
1	PHASE PIN CAL.20		4	
Ind	Description	Reference	Cont.	Strip. A

Frédéric RUSSO
2013.10.23 11:08:45 +02'00'

PRODUCT REFERENCE

899.AS8AM424
899.AS8AM430

SCAME
S.p.A.
PARRE - (Bergamo)
zp90982-43-2_mp39432

ASSEMBLY INSTRUCTIONS

- 1- PREPARE THE CABLES AS SCHEME BELOW.
- 2- CRIMP OR SOLDER CABLE TERMINALS (2) ON PHASE CABLES AND EARTH CABLE [TOOL Nr 9 AND 10].
- 3- SEPARATE NUT (5.5) FROM FLANGE (5.1) [TOOL Nr 5].
- 4- UNSCREW SUPPORT (5.4) [TOOL Nr 8].
- 5- IN THE ORDER, SLIDE SEAL (5.3), FLANGE (5.1), SLIDING WASHER (5.2) AND SUPPORT (5.4) OVER THE CABLE.
- 6- REMOVE SCREWS OF CONTACTS (3) [TOOL Nr 7], INTRODUCE CONTACTS IN FRONT OF CONTACT CARRIER (4). CONTACTS MUST GO OUT OF CONTACT CARRIER, IF NO RETURN CONTACT CARRIER. INTRODUCE PILOT CABLES IN BACKSIDE OF CONTACTS AND PUT SCREWS IN CONTACTS THEN TIGHTEN [TOOL Nr 7].
- 7- INTRODUCE CONTACTS (1) IN FRONT OF CONTACT CARRIER (4). INTRODUCE EACH CABLE TERMINAL (2) AT THE BACKSIDE OF CONTACTS (1), THEN SCREW CONTACTS (1) (TORQUE 25Nm) [TOOL Nr 1, 2 AND 3]
BLOCKING CABLE TERMINALS (2) IN GROOVE OF INSERT.
- 8- ENGAGE EARTH CONTACT (6) IN THE HOLE OF EARTH EAR IN THE MIDDLE OF INLET CASING (5).
- 9- PLACE CABLE TERMINAL (2) OF EARTH CABLE AT THE BACKSIDE OF EARTH CONTACT (6), SCREW CONTACT,
WHEN CABLE TERMINAL HEXAGON TOUCH EARTH EAR OF INLET CASING (5), PUSH IT INSIDE OF EARTH EAR TO BLOCK IT, THEN TIGHTEN CONTACT (6) (TORQUE 25Nm) [TOOL Nr 1; 2 AND 3].
- 10- FIX CONTACT CARRIER (4) ON SUPPORT (5.4) [TOOL Nr 6].
- 11- FIX INLET CASING (5) ON SUPPORT (5.4) [TOOL Nr 8].
- 12- PLACE NUT (5.5) ON INLET CASING (5) THEN PLACE SLIDING WASHER (5.2) AND FLANGE (5.1), TIGHTEN ALL PARTS [TOOL Nr 5]. BE CAREFUL TO NOT CAUGHT SLIDING WASHER (5.2) BETWEEN FLANGE (5.1) AND NUT (5.5).
- 13- PLACE SEAL (5.3) AT THE BACKSIDE OF SUPPORT (5.4).

LIST OF TOOLS *

- 1- TORQUE WRENCH FACOM REF: J.306A50
- 2- INCREASER 3/8" TO 1/2" FACOM REF: J.232
- 3- SOCKETS FACOM : 1/2" Nr30 REF: S.30LA
- 4- ANGLED SOCKET WRENCH OR OPEN END WRENCH 10mm
- 5- FLAT SCREWDRIVER Nr 6.5
- 6- FLAT SCREWDRIVER Nr 3
- 7- ALLEN KEY Nr 4
- 8- CRIMPING TOOL KLAUKE HK 120 U
- 9- KLAUKE CRIMPING JAW: 240° REF: HNFF 13/240
400° REF: HNF 13/400

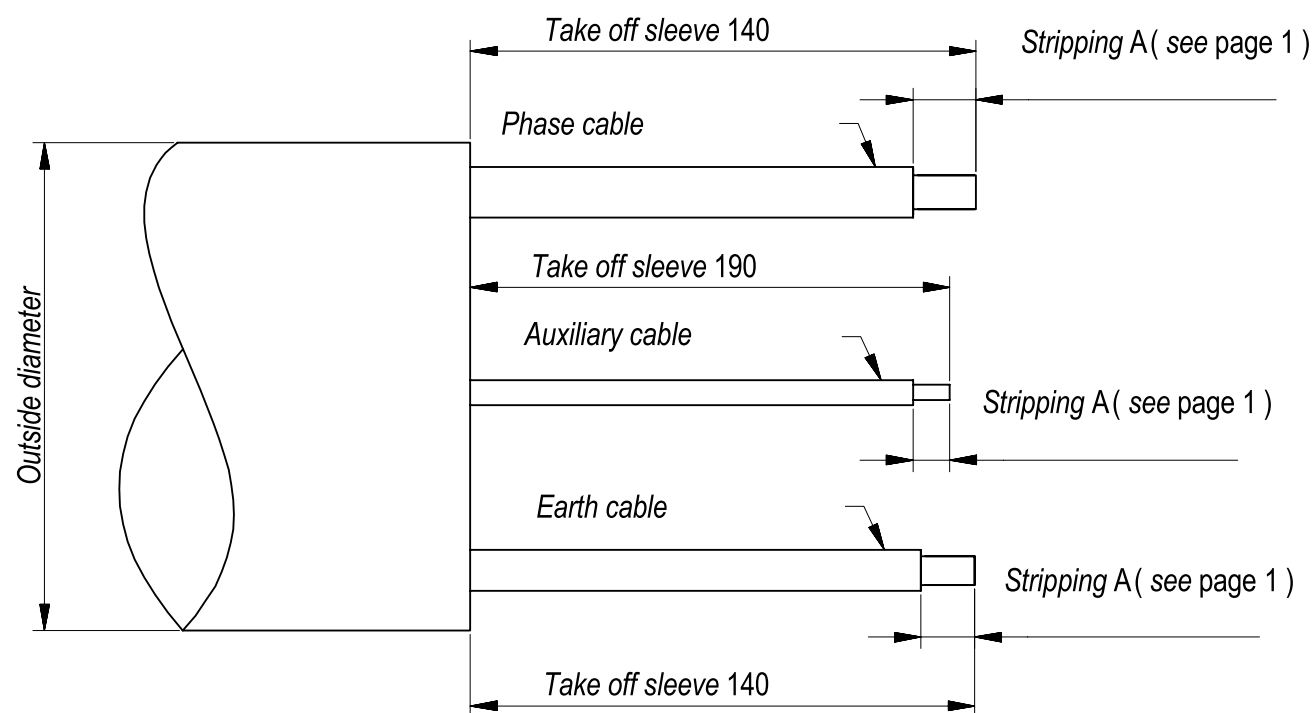

Frédéric RUSSO
2013.10.23 11:06:58 +02'00'

SCAME
S.p.A.
PARRE - (Bergamo)
zp90982-43-2_mp39432

* TOOL REFERENCES ARE ONLY RECOMMENDED AND GIVEN AS EXAMPLES. TOOLS ARE NOT PROVIDED OR IMPOSED BY SCAME.