

6	SOCKET CASING		1	
5	AUXILIARY FEMALE CONTACT CAL.4		2	19
4	PHASE FEMALE CONTACT CAL.20		4	
3	EARTH FEMALE CONTACT CAL.20		1	
2	4+E FEMALE CONTACT CARRIER		1	
	CABLE TERMINAL TO CRIMP OR SOLDER 300 ²			48
1	CABLE TERMINAL TO CRIMP OR SOLDER 240 ²			42
Ind	Description	Reference	Cont.	Strip. A

Filippo RUSSO
2013.10.23 10:51:10 +0200

PRODUCT REFERENCE

899.AS8DF424
899.AS8DF430

SCAME
S.p.A.
PARRE - (Bergamo)
zp90982-37-2_mp39426

ASSEMBLY INSTRUCTIONS

- 1- PREPARE THE CABLES AS SCHEME BELOW.
- 2- CRIMP OR SOLDER CABLE TERMINALS (1) ON PHASE CABLES AND EARTH CABLE [TOOL Nr 7 AND 8].
- 3- SLIDE SEAL (6.1) AND SOCKET (6) OVER THE MAIN CABLE.
- 4- REMOVE SCREWS OF CONTACTS (5) [TOOL Nr 5], INTRODUCE CONTACTS IN FRONT OF CONTACT CARRIER (2). INTRODUCE PILOT CABLES IN BACKSIDE OF CONTACTS AND PUT SCREW IN CONTACTS THEN TIGHTEN [TOOL Nr 5].
- 5- INTRODUCE CONTACTS (4) IN THE FRONT OF CONTACT CARRIER (2).
- 6- INTRODUCE EACH PHASE CABLE TERMINAL (1) AT THE BACKSIDE OF CONTACTS (4) THEN SCREW WITH THE HAND. BLOCK CABLE TERMINALS IN GROOVE OF INSERT AND TIGHTEN CONTACTS (4) IN THE FRONT (TORQUE 25Nm) [TOOL Nr 1; 2 AND 3].
- 7- INTRODUCE CONTACT CARRIER (2) IN THE SOCKET CASING (6) AND FIX IT [TOOL Nr 6].
- 8- ENGAGE EARTH CONTACT (3) IN THE HOLE OF EARTH EAR IN THE MIDDLE OF SOCKET (6).
- 9- PLACE CABLE TERMINAL (1) OF EARTH CABLE AT THE BACKSIDE OF EARTH CONTACT (3), SCREW CONTACT, WHEN CABLE TERMINAL HEXAGON TOUCH EARTH EAR OF SOCKET CASING (6), PUSH IT INSIDE OF EARTH EAR TO BLOCK IT, THEN TIGHTEN CONTACT (3) (TORQUE 25Nm) [TOOL Nr 1; 2 AND 3].
- 10- PLACE SEAL (6.1) AT THE BACKSIDE OF SOCKET CASING(6).

LIST OF TOOLS *

- 1- TORQUE WRENCH FACOM REF. J.306A50
- 2- SOCKETS FACOM : 1/2" Nr30 REF: S.30
- 3- INCREASER FACOM 3/8" TO 1/2" REF: J.232
- 4- FLAT SCREWDRIVER Nr 3
- 5- FLAT SCREWDRIVER Nr 6,5
- 6- CRIMPING TOOL KLAUKE HK 120 U
- 7- KLAUKE CRIMPING JAW: 240² REF: HNFF 13/240
400² REF: HNF 13/400

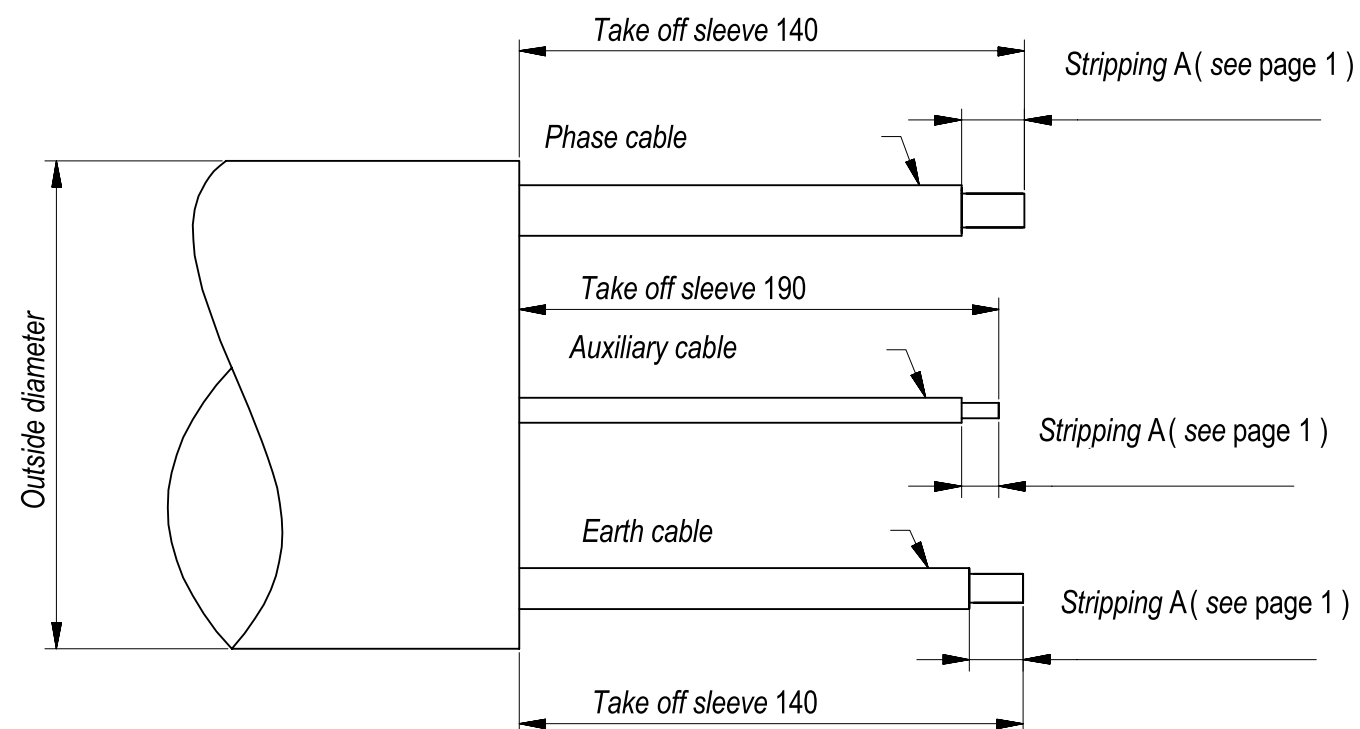

Frédéric RUSSO
2013.10.23 10:51:30 +02'00'

SCAME

S.p.A.

PARRE - (Bergamo)

zp90982-37-2_mp39426